

Maritime Strike Platform

Midn 1/C Mason Kruljac, Evan Prince, Max Rubin, Sapphaira Trantham and Prof. Jenelle Piepmeier

Motivation

The goal of this project is to bridge critical gaps in today's market by providing solutions that are practical, innovative, and cost-effective. In the end, warfighting capabilities can adapt to evolving conflicts and rising global tensions. This project will focus on grassroots technological innovation and expertise to provide an alternative to costly industrial research and development and fielding of equipment.



Ukrainian Magura Naval Drone boats at work in the Black Sea

Vessel Design

For testing, a Cocktail class racing vessel was used. In addition, another plywood boat was built in ~70 hours using basic instructions for a "Poor Boy" design, to outline what can be built with little experience and widely available materials.



Cocktail class racing vessel in testing



Completed "Poor Boy" boat

The control arm was designed to be strong, adaptable to different vessels and easily 3D printed. High infill and material selection allow for adequate strength.

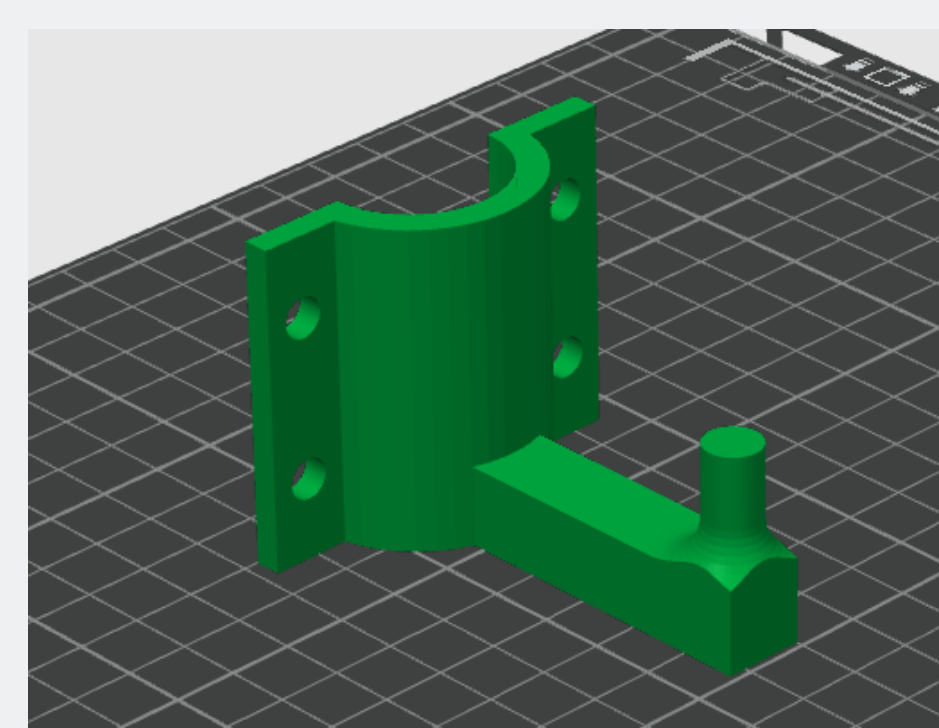

Design for the 3D printed control arm

Autonomous System

The backbone of the autonomous system. Is a Pixhawk Cubepilot running ArduRover mission planning software. This hardware setup creates a vessel that is capable of navigating waypoint to waypoint. There is also the added benefit of being easily reconfigurable and adaptable to new hardware.

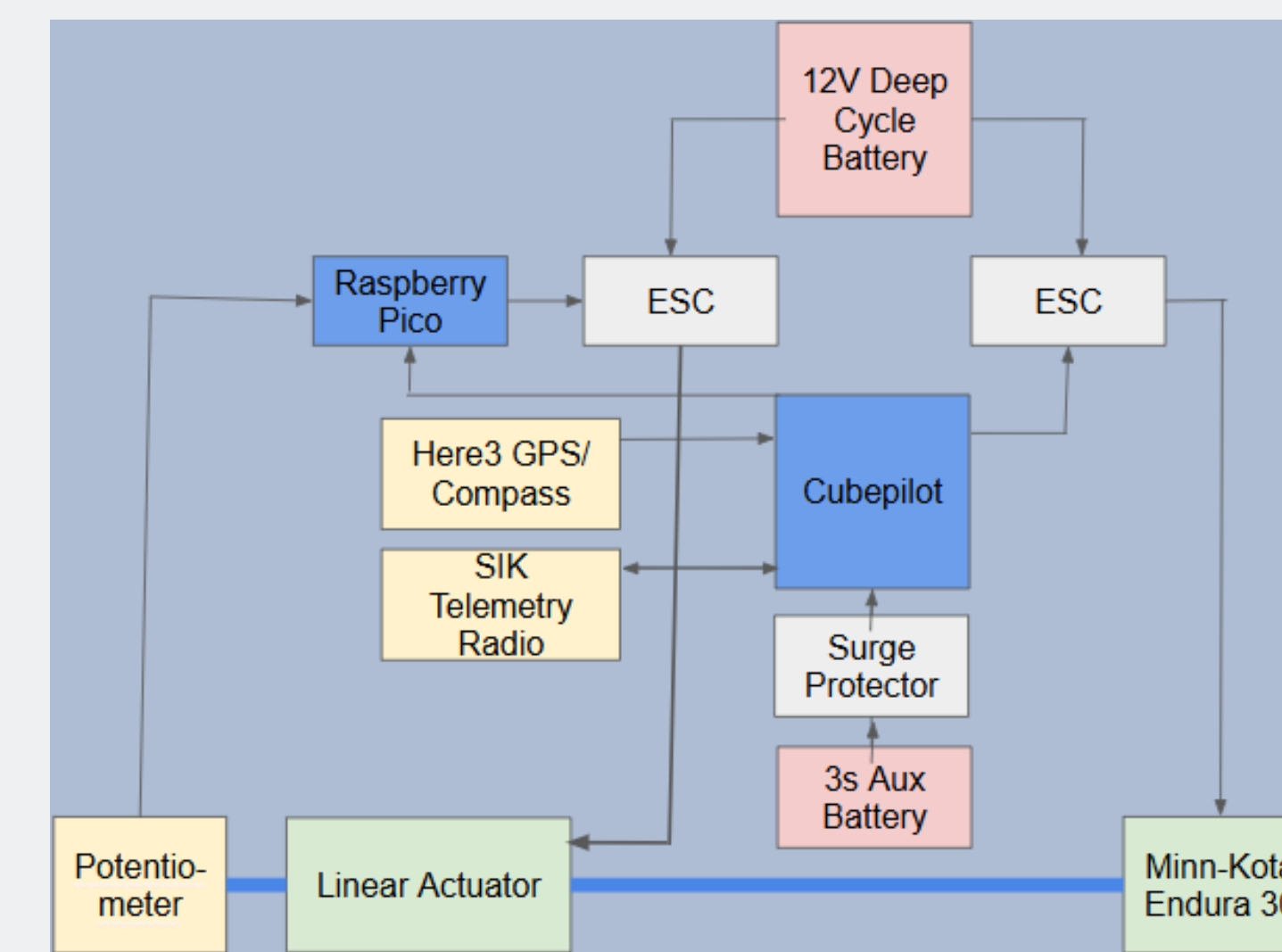

System Architecture Diagram

The boat is propelled by an electric trolling motor and steered with a linear drive. The potentiometer provides feedback on the boat's rudder angle. There is a disconnect between how the Cubepilot interprets the rudder's angle, so the Raspberry Pico bridges that gap. The Here3 GPS updates the boat's location and bearing while the SIK Telemetry Radio provides the link between the boat and the ground control station. Each actuator has its own ESC, and they are powered by a 12V deep cycle battery.



Waypoint Mission Example

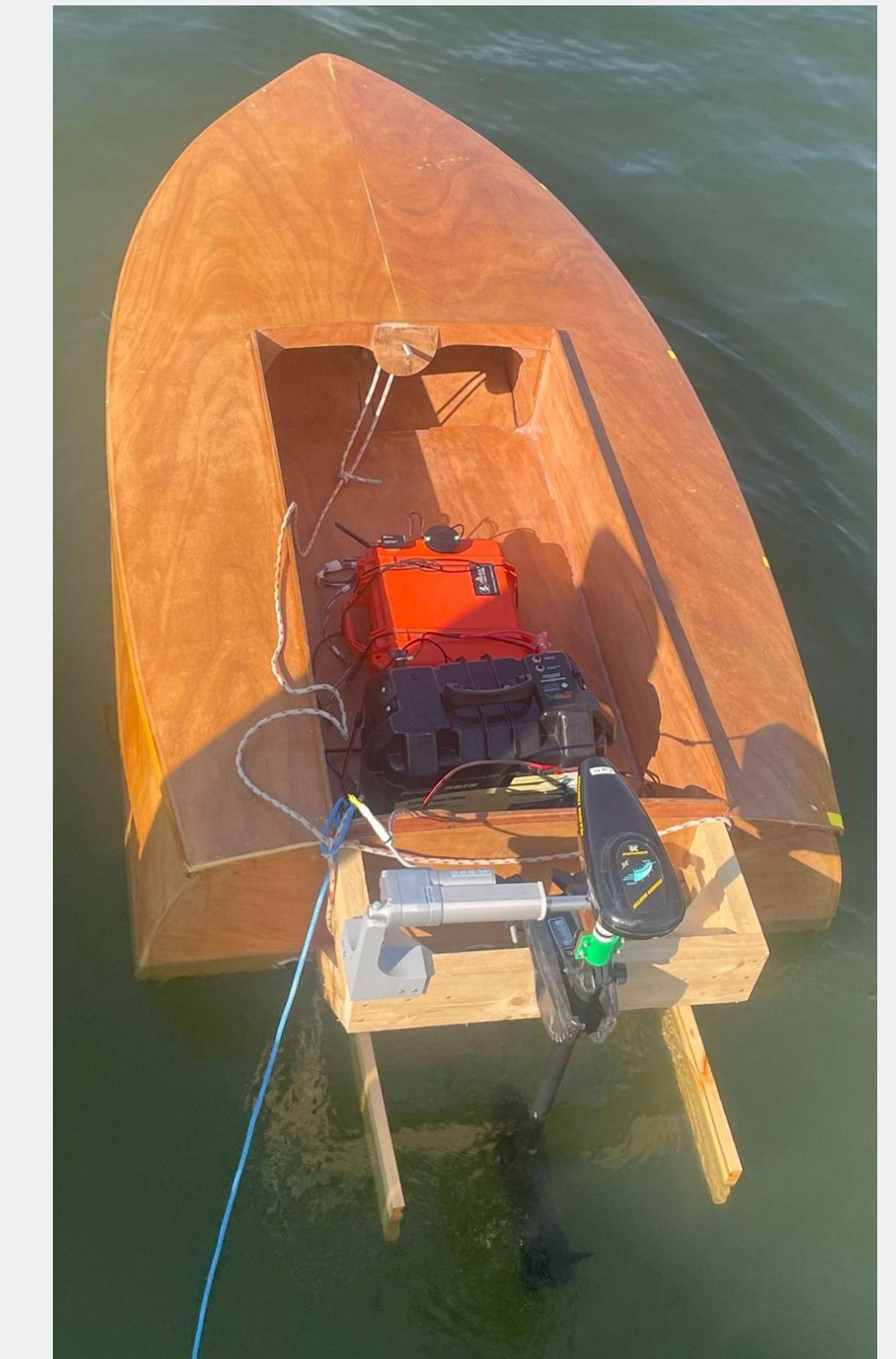

Cockpit and Motor Setup

Problem Statement

Design a seaworthy, easily manufactured autonomous vessel capable of transiting at least 40 nautical miles, operating for over 24 hours, and detecting and identifying other vessels while delivering payloads.

Military Application

The US Navy currently uses GARCs manufactured by BlackSea Technologies for intelligence, surveillance, and reconnaissance (ISR) mission sets through their new USV squadrons.



GARCs at work. Source: BlackSea Technologies

Conclusion

Wood and fiberglass are ideal materials for constructing simple, but durable small maritime craft. The materials are cheap, lightweight, and absorb vibrations well. A deep V-hull could be utilized to improve stability in open sea applications of the vessel.

The Cubepilot and Here3 GPS module are both capable of maintaining navigation and control of the boat for extended periods of time. For actual combat missions, the boat would be better equipped with a large gas motor, a deeper hull, and improved long-range communications hardware.



Acknowledgements

We would like to thank SOCOM-Ignite, MIT-LL, Professor Morabito, Professor Feemster, LCDR Gregory A. Chauncey '62 and Mrs. Naomi C. Broering, the Class of 1977 Captain Owen G. Thorp Memorial Fund, and the Support Technicians from the Rickover Machine Shop and WRC TSD.